

BD 7/7 M4 0,12kW (251100260)

GENERAL DATA



FAN DOUBLE INLET

MANUFACTURING FEATURES:

- Galvanised steel sheet housing.
- Double inlet forward curved impeller in all models. Turbine fiber reinforced glass sizes 7-7, 9-9, 10/10 and 12/12. Other models in galvanized sheet.
- Supplied with mounting feet (included in price).
- Exclusive system Casals fixing motor and turbine fan by flexible arms silent blocks to avoid any vibration. Arms in compliance with ROHS regulations 2002/95 / EC (Restriction of Hazardous Substances in electrical and electronic equipment)
- Closed motors specially designed Casals: extruded aluminum housing, all protected inside the terminal box, built-in motor with IP65 connections.
- Motor with IP55 protection and Class F insulation standard voltages: 230V 50Hz in single phase and 230 / 400V 50Hz three-phase.
- Single phase voltage controllable. Adjustable phase models suitable for inverter.

APPLICATIONS:

Designed for assembly in equipment:

- Ventilation boxes and air handling units.
- Centrifugal heaters.
- Industrial and professional kitchen hoods.
- Maximum working temperature: 50°C.

UNDER REQUEST

- Impeller made of galvanized steel sheet.
- MBI assembled

CHARACTERISTIC CURVE

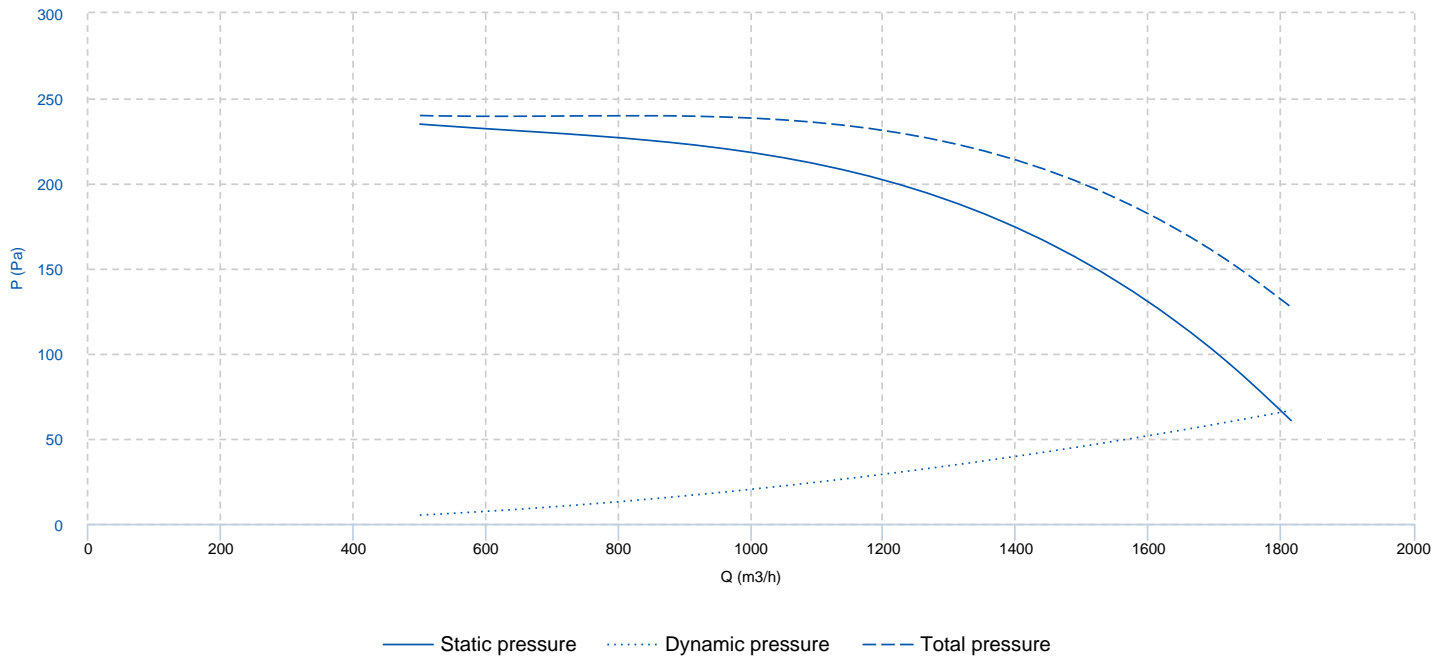

TECHNICAL DATA

fan

RPM	1370	approx. weight	9 kg	max flow	1820 m ³ /h
-----	------	----------------	------	----------	------------------------

motor

power	0,12 kW	motor rpm	1370	Capacitor	9µF 400V
imax 230V	1,5 A	size	63	approx. weight	4,1 kg
FP	0,98				

DIMENSIONS DIAGRAM

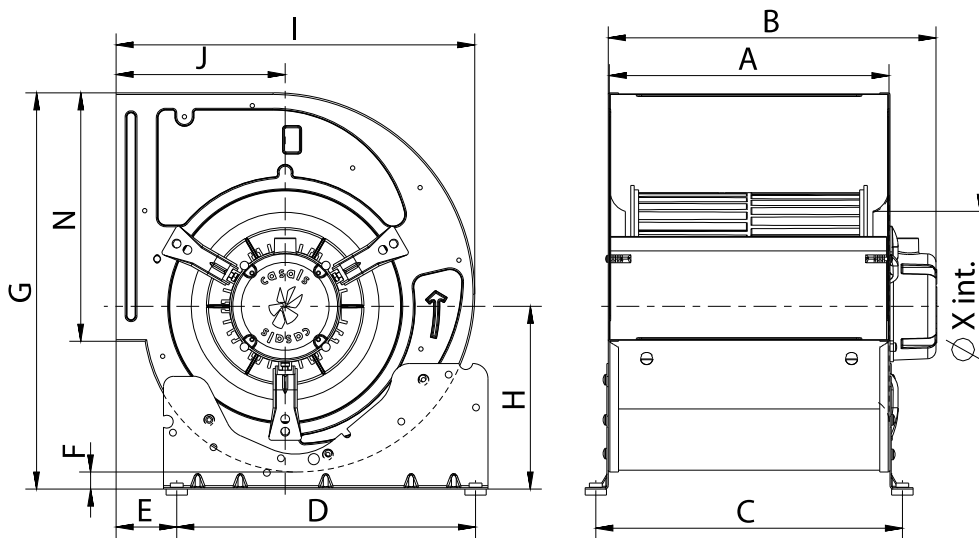

Dimensions (mm)

A	230	B máx	302	C	259	D	245	E	48,5
F	9,5	G	337	H	150	I	316	J	153
N	208	X	158						

WIRING DIAGRAM

**SINGLE PHASE MOTOR
MOTOR MONOFÁSICO**

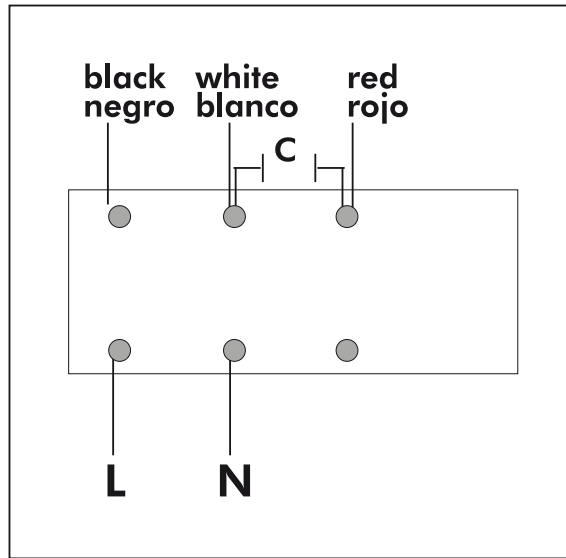

ACCESSORIES



SINGLE PHASE MANUAL SPEED CONTROLLER
REG 1.5A
REF: 960710015